



aerospace  
climate control  
electromechanical  
filtration  
fluid & gas handling  
**hydraulics**  
pneumatics  
process control  
sealing & shielding



## Air Oil Coolers

LHC with Hydraulic Motor for Mobile and Industrial Use



ENGINEERING YOUR SUCCESS.



The Olaer Group is part of Parker Hannifin since July 1st, 2012. With manufacturing and sales in 14 countries in North America, Asia and Europe, the Olaer Group expands Parker's presence in geographic growth areas and offers expertise in hydraulic accumulator and cooling systems for target growth markets such as oil and gas, power generation and renewable energy.

## LHC Air Oil Coolers

For mobile and industrial use - maximum cooling capacity 300 kW

The LHC air oil cooler with hydraulic motor is optimized for use in the mobile and industrial sector. Together with a wide range of accessories, the LHC cooler is suitable for installation in most applications and environments. The maximum cooling capacity is 300 kW at ETD 40 °C. Choosing the right cooler requires precise sizing. The most reliable way to size is with the aid of our calculation program. This program, together with precise evaluations from our experienced, skilled engineers, gives you the opportunity for more cooling per € invested.

### Overheating - an expensive problem

An under-sized cooling capacity produces a temperature

balance that is too high. The consequences are poor lubricating properties, internal leakage, a higher risk of cavitation, damaged components, etc. Overheating leads to a significant drop in cost-efficiency and environmental consideration.

### Temperature optimisation - a basic prerequisite for cost-efficient operation

Temperature balance in a hydraulic system occurs when the cooler can cool down the energy input that the system does not consume - the system's lost energy:

( $P_{loss} = P_{cool} = P_{in} - P_{used}$ ).

Temperature optimisation means that temperature balance occurs at the system's ideal working temperature - the temperature at which the oil's

viscosity and the air content comply with recommended values.

### The correct working temperature produces a number of economic and environmental benefits:

- The hydraulic system's useful life is extended.
- The oil's useful life is extended.
- The hydraulic system's availability increases – more operating time and fewer shutdowns.
- Service and repair costs are reduced.
- High efficiency level maintained in continuous operation – the system's efficiency falls if the temperature exceeds the ideal working temperature.

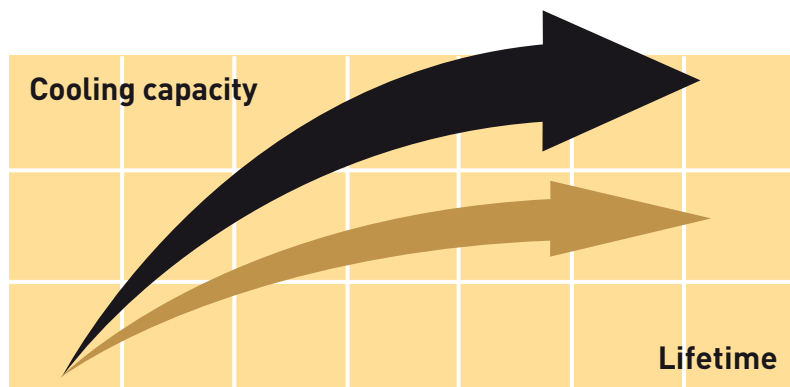

Clever design and the right choice of materials and components produce a long useful life, high availability and low service and maintenance costs.

Compact design and low weight.

Easy to maintain and easy to retrofit in many applications.



Hydraulic motor with displacement from 8.4 cm<sup>3</sup>/r to 25.2 cm<sup>3</sup>/r.

Collar bearing for fan motor on larger models provides longer useful life.

Quiet fan and fan motor.

Cooler matrix with low pressure drop and high cooling capacity.

## LHC-M and LHC-X

LHC air oil coolers are also available in two special versions, LHC-X (ATEX version), approved

for applications where there may be an explosive environment above ground, and LHC-M,

adapted to be able better to deal with corrosion attacks, for example in marine environments.

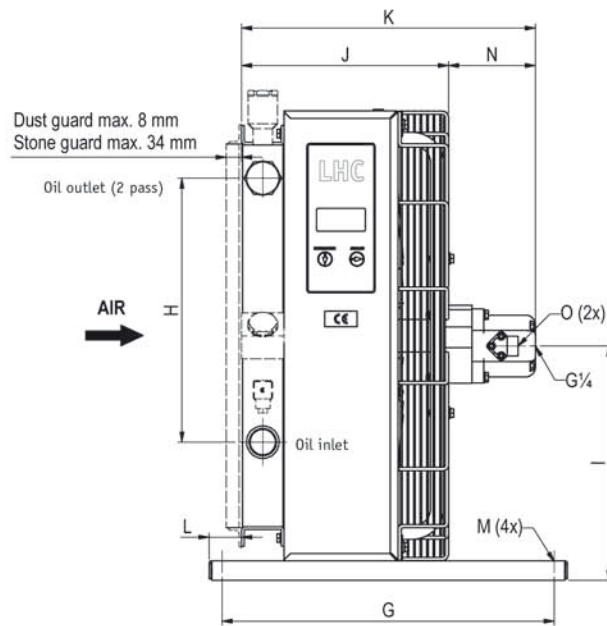

TYPE	Fan speed rpm	Fan capacity kW	Weight kg (approx)	Max fan speed rpm @ 40 °C	Acoustic pressure level LpA dB(A) 1m*
LHC2 007	1500	0.10	10	3500	62
	3000	0.65	10	3500	79
LHC2 011	1500	0.20	15	3500	67
	3000	1.50	15	3500	82
LHC2 016	1000	0.10	18	3500	60
	1500	0.35	18	3500	70
	3000	2.50	18	3500	86
LHC2 023	1000	0.15	30	3500	64
	1500	0.50	30	3500	76
LHC 033	1000	0.65	40	2900	75
	1500	2.00	40	2900	85
LHC 044	1000	0.70	56	2900	77
	1500	2.00	56	2900	86
LHC 056	750	0.75	70	2400	74
	1000	1.80	70	2400	82
LHC 058	750	0.75	77	2400	75
	1000	1.80	77	2400	83
LHC 076	750	0.70	105	2200	80
	1000	1.60	105	2200	87
LHC 078	750	0.70	111	2200	81
	1000	1.60	111	2200	88
LHC 110	750	1.70	117	1900	85
	1000	4.00	117	1900	91
LHC 112	750	1.70	125	1900	86
	1000	4.00	125	1900	92
LHC 113	750	1.70	184	2400	87
	1000	4.00	184	2400	93
LHC 200	Please contact Parker for more information				

\* = Noise level tolerance  $\pm 3$  dB(A).



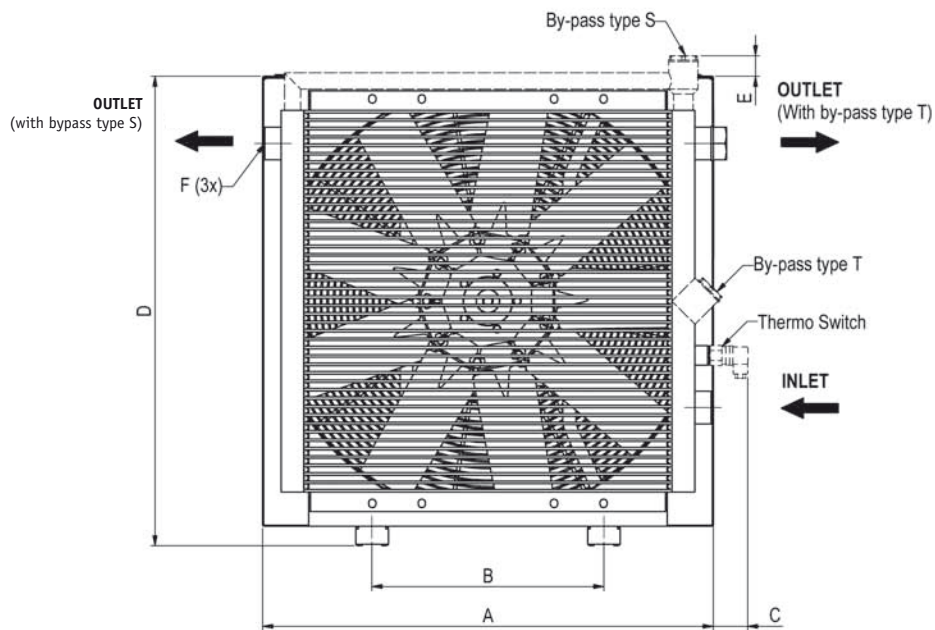

TYPE	A	B	C	D	E	F	G	H	I	J	K	L	Mø
LHC2 007	365	203	64	395	42	G1	510	160	197	225	J+N	50	9
LHC2 011	440	203	62	470	41	G1	510	230	234	249	J+N	50	9
LHC2 016	496	203	66	526	46	G1	510	230	262	272	J+N	50	9
LHC2 023	580	356	44	610	44	G1	510	305	304	287	J+N	50	9
LHC 033	692	356	42	722	42	G1¼	510	406	360	318	J+N	50	9
LHC 044	692	356	59	866	59	G1¼	510	584	432	343	J+N	50	9
LHC 056	868	508	49	898	43	G1¼	510	584	448	368	J+N	50	9
LHC 058	868	508	49	898	43	G2	510	584	448	388	J+N	30	9
LHC 076	1022	518	41	1052	45	G1½	610	821	525	393	J+N	70	14
LHC 078	1022	518	41	1052	45	G2	610	821	525	413	J+N	50	14
LHC 110	1185	600	54	1215	45	G2	610	985	607	418	J+N	70	14
LHC 112	1185	600	54	1215	45	G2	610	985	607	438	J+N	50	14
LHC 113	1200	600	82	1215	45	G2	610	985	607	485	J+N	132	14

MOTOR	Displacement cm <sup>3</sup> /r	N LHC2 007 – LHC2 023	N LHC 033 – LHC 112	O Angular 90° connection	Max. working pressure bar
A	8.4	91	133	G½	250
B	10.8	98	138	G½	250
C	14.4	101	144	G½	250
D	16.8	105	148	G¾	250
E	19.2	110	151	G¾	250
F	25.2	120	165	G¾	250



The cooling capacity curves are based on the inlet oil temperature and the ambient air temperature. An oil temperature of 60 °C and an air temperature of 20 °C produce a temperature difference of 40 °C. Multiply by kW/°C for total cooling capacity.

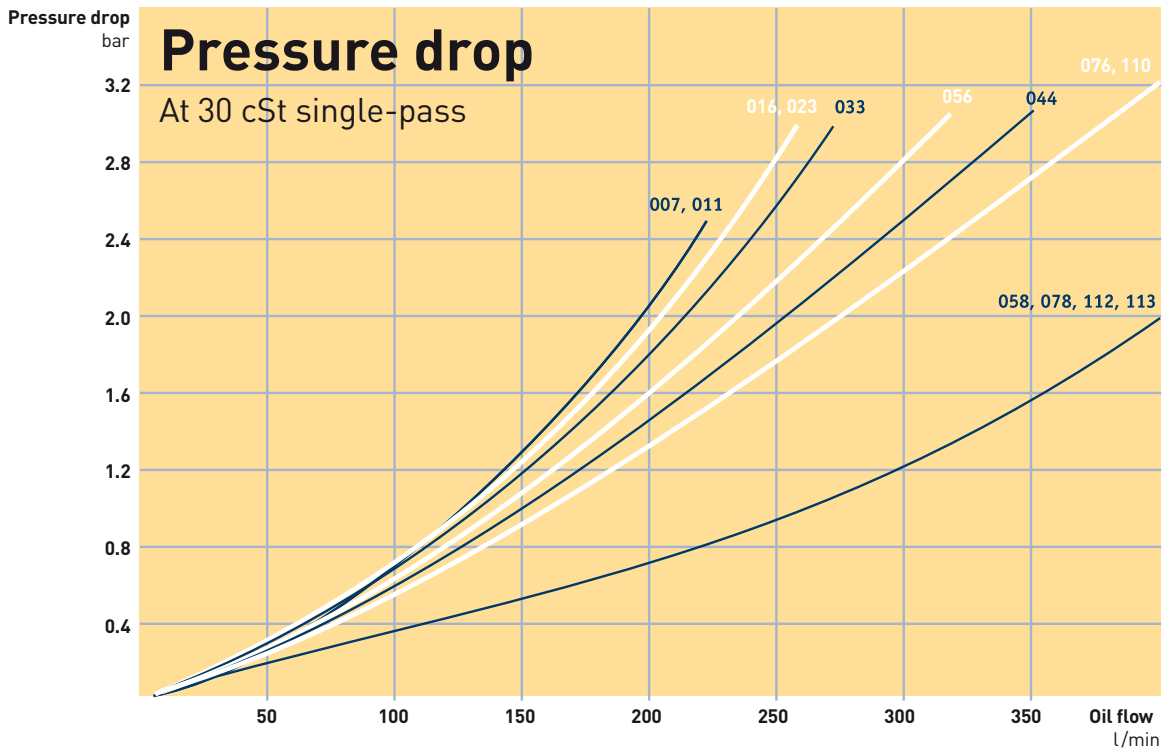

Cooling capacity  
kW/°C

# Cooling capacity

LHC 033 – LHC 113

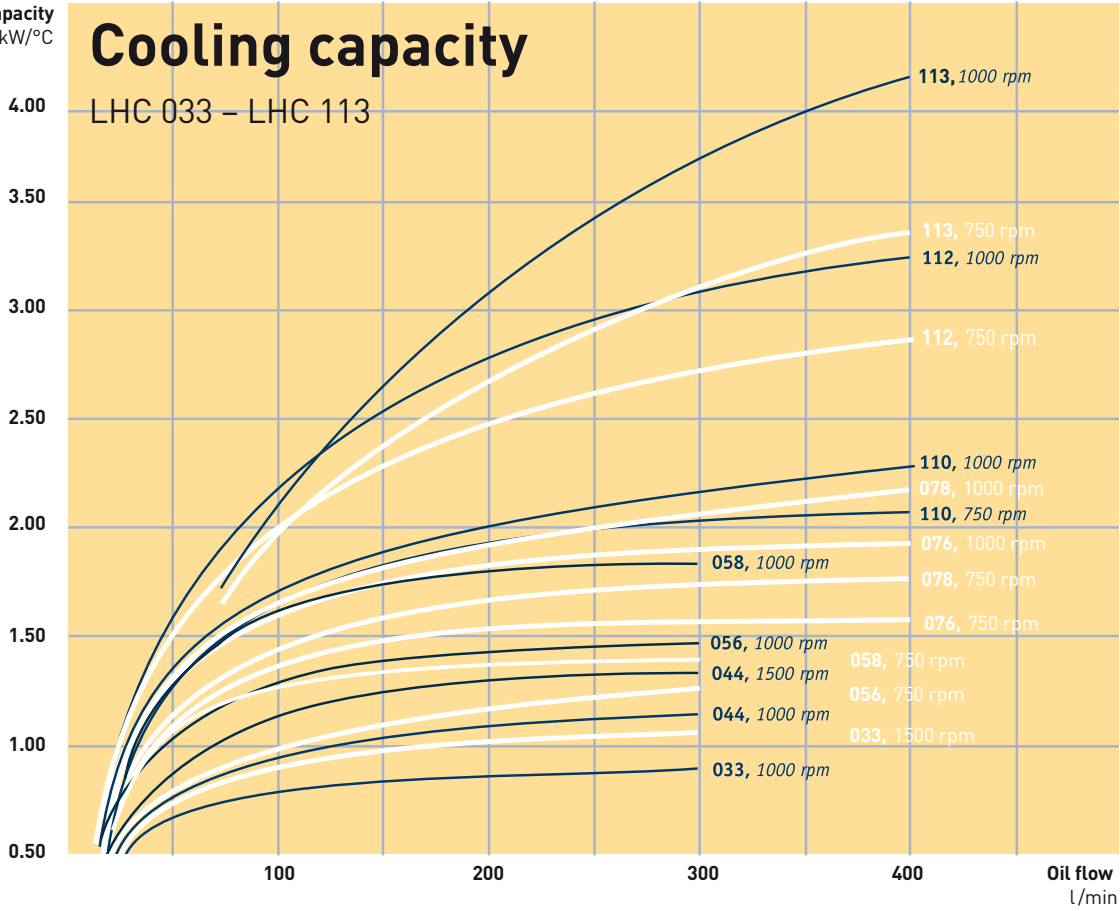

Cooling capacity  
kW/°C

# Cooling capacity

LHC 007 – LHC 023

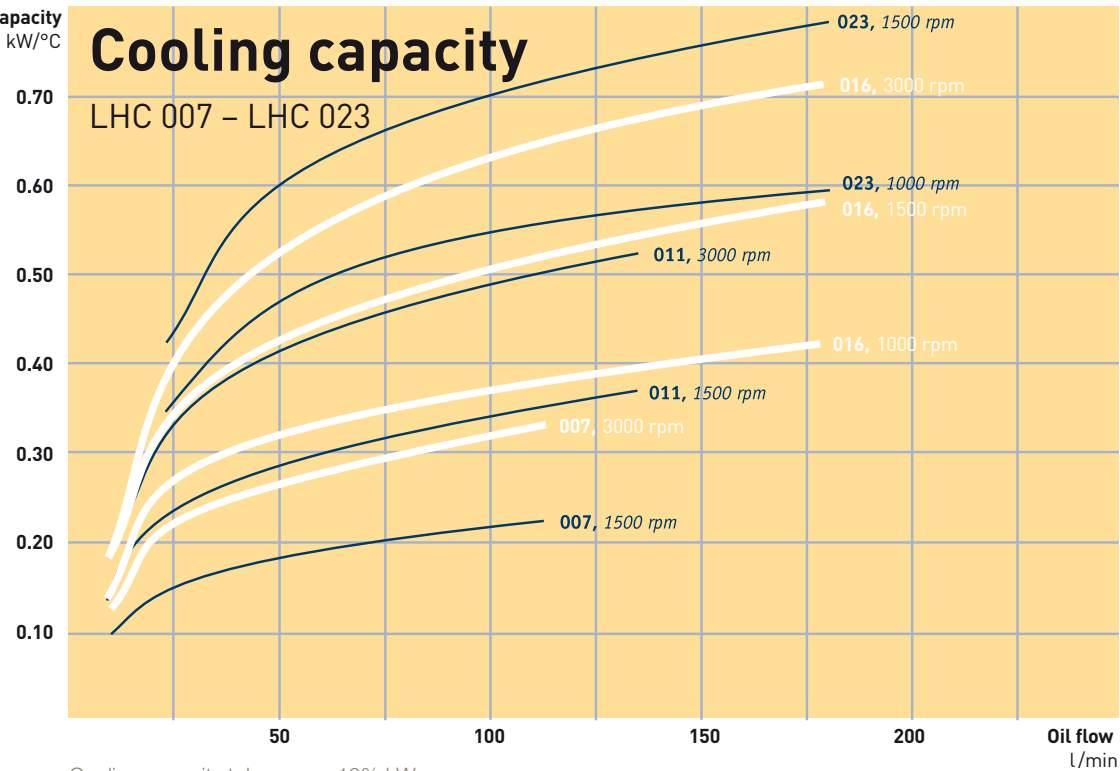

Cooling capacity tolerance  $\pm 10\%$  kW.



# Key for LHC/LHC2 Air Oil Coolers

All positions must be filled in when ordering

EXAMPLE: LHC2 - 016 - B - 50 - S20 - S - Z  
 1 2 3 4 5 6 7

## 1. AIR OIL COOLER WITH HYDRAULIC MOTOR = LHC / LHC2

### 2. COOLER SIZE

007, 011, 016, 023, 033, 044, 056, 058, 076, 078, 110, 112 and 113.

### 3. HYDRAULIC MOTOR, DISPLACEMENT

No hydraulic motor	= O
Displacement 8.4 cm <sup>3</sup> /r	= A
Displacement 10.8 cm <sup>3</sup> /r	= B
Displacement 14.4 cm <sup>3</sup> /r	= C
Displacement 16.8 cm <sup>3</sup> /r	= D
Displacement 19.2 cm <sup>3</sup> /r	= E
Displacement 25.2 cm <sup>3</sup> /r	= F
Special	= X

(X: pressure, displacement, installation sizes, etc. must be stated in plain language)

### 4. THERMO CONTACT

No thermo contact	= 00
40 °C	= 40
50 °C	= 50
60 °C	= 60
70 °C	= 70
80 °C	= 80
90 °C	= 90

### 5. COOLER MATRIX

Standard	= 000
Two-pass	= T00
<b>Built-in, pressure-controlled bypass, single-pass</b>	
2 bar	= S20
5 bar	= S50
8 bar	= S80
<b>Built-in, pressure-controlled bypass, two-pass*</b>	
2 bar	= T20
5 bar	= T50
8 bar	= T80
<b>Built-in temperature and pressure-controlled bypass, single-pass</b>	
50 °C, 2.2 bar	= S25
60 °C, 2.2 bar	= S26
70 °C, 2.2 bar	= S27
90 °C, 2.2 bar	= S29

### Built-in temperature and pressure-controlled bypass, two-pass\*

50 °C, 2.2 bar	= T25
60 °C, 2.2 bar	= T26
70 °C, 2.2 bar	= T27
90 °C, 2.2 bar	= T29

### 6. MATRIX GUARD

No guard	= 0
Stone guard	= S
Dust guard	= D
Dust and stone guard	= P

### 7. STANDARD/SPECIAL

Standard	= O
Special	= Z

## TECHNICAL SPECIFICATION

### FLUID COMBINATIONS

Mineral oil	HL/HLP in accordance with DIN 51524
Oil/water emulsion	HFA, HFB in accordance with CETOP RP 77H
Water glycol	HFC in accordance with CETOP RP 77H
Phosphate ester	HFD-R in accordance with CETOP RP 77H

### MATERIAL

Cooler matrix	Aluminum
Fan blades/hub	Glass fibre reinforced polypropylene/Aluminum
Fan housing	Steel
Fan guard	Steel
Other parts	Steel
Surface treatment	Electrostatically powder-coated

### COOLER MATRIX

Maximum static operating pressure	21 bar
Dynamic operating pressure	14 bar*
Heat transfer limit	± 6 %
Maximum oil inlet temperature	120 °C

\* Tested in accordance with ISO/DIS 10771-1

### COOLING CAPACITY CURVES

The cooling capacity curves in this technical data sheet are based on tests in accordance with EN 1048 and have been produced using oil type ISO VG 46 at 60 °C.

### CONTACT PARKER HANNIFIN FOR ADVICE ON

- Oil temperatures > 120 °C
- Oil viscosity > 100 cSt
- Aggressive environments
- Ambient air rich in particles
- High-altitude locations

### CONNECTION CHART

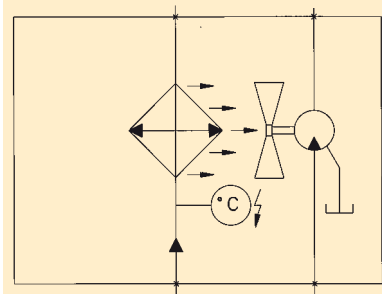

Connection chart for LHC air oil cooler.

The information in this brochure is subject to change without prior notice.